

MEASUREMENT OF SMALL MOISTURE BY THE IDC MOISTURE METERS.

The measurement of very small water content (0,01 and 0,001 %) in a manufacturing process is the relevant problem for such materials as sugar, talc, plastics, kaolin, alumina, chemical and pharmaceutical materials etc.



The IDC201-1 open $\lambda/4$ resonator on-line moisture meter is designed for continuous moisture measuring in powders and granules, and provides measurements that are insensitive to sample preparation, including variations in bulk density. The device's sensor can be mounted in places of material free fall in pipes during flour transferring, above loading bunkers and other places. The complete set of delivery of the device includes the program of storage and displaying of moisture real-time, that allows to enter into the computer, to watch, to store and to print the information on moisture for any span.

The sensor is loaded with falling material and at regular intervals is unloaded with the help of compressed air 2-4 atm.

How The Meter Works



The sensor operates as a transmission mode, open resonator, which supports a simple TEM resonance mode. Coupling of energy between the test material and the sensor is via the fringing fields. These fields act as an effective capacitance and conductance, and determine the values of f and Q for the resonator, which in turn can be related to the moisture content of the material under test. Design features of the resonator reduce artifacts from environmental and extraneous conditions, such as positioning and vibration.

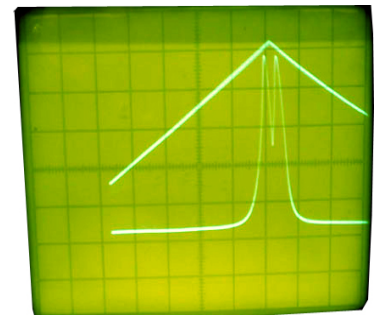

Product Specification

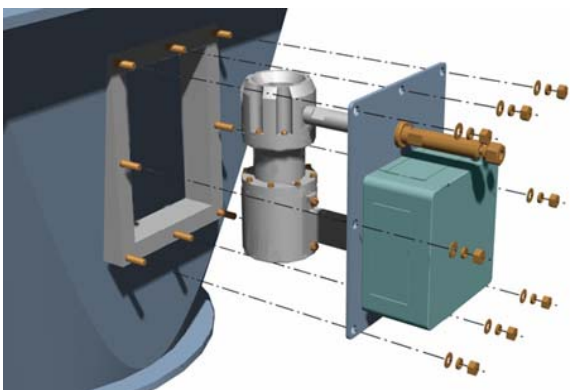

- Range1 of moisture measurement: 0-1,5%
- Range2 of moisture measurement: 0-0,1%
- Display resolution, in % moisture: 0.1%
- Accurate (1 SD) for Range1 $\pm 0.025\%$
- Accurate (1 SD) for Range2 $\pm 0.006\%$
- Ease of installation on-line
- Continuous measurement of moisture
- Stable calibration
- Dust and water protected to IP54 standard

IDC201-1. Main technical characteristics as applied to some materials

Material	Measurement range	Sensitivity	Accuracy (1SD)
Dry milk	2,0-7,0 %	0,01%	0,15%
Casein	5,0-14,0 %	0,01%	0,15%
Quartz sand	0-1,5 %	0,01 %	0,05 %
Apatite powder	0-3 %	0,01 %	0,1 %
Malt	1-6 %	0,01 %	0,15 %
Nifelin powder	0-3 %	0,01 %	0,1 %
Salt	0-0,25 %	0,001 %	0,005 %

The applying of microwave resonators allows to decide a number of problems, however for moisture of smaller 0,01 % we collide with a number of technical problems. The sensitivity of such resonators is limited not only small amount of a measured material, but also Q-factor of a resonator. The radiation losses are a pacing factor of a decrease of Q-factor and desensitization a quarter of wave opened resonators



Ours the half-wave resonator moisture meter IDC201-2 with full filling of a resonator and pneumatic unloading of the measuring chamber allows to measure moisture from 0,001 % and less with satisfactory sensitivity and accuracy.

IDC201-2. Main technical characteristics as applied to some materials

Material	Measurement range	Sensitivity	Accuracy (1SD)
Sugar	0,01-0,06 %	0,001 %	0,002%
Salt	0-0,25 %	0,001 %	0,005 %
Carbamide	0-0,6 %	0,001 %	0,005 %
Plastic powder very small density	0,01-0,1 %	0,001 %	0,003 %
Quartz dry sand	0-0,1 %	0,001 %	0,002 %
Alumina	0-0,3 %	0,001 %	0,003 %

Applying of our resonator moisture meters in the some industries.

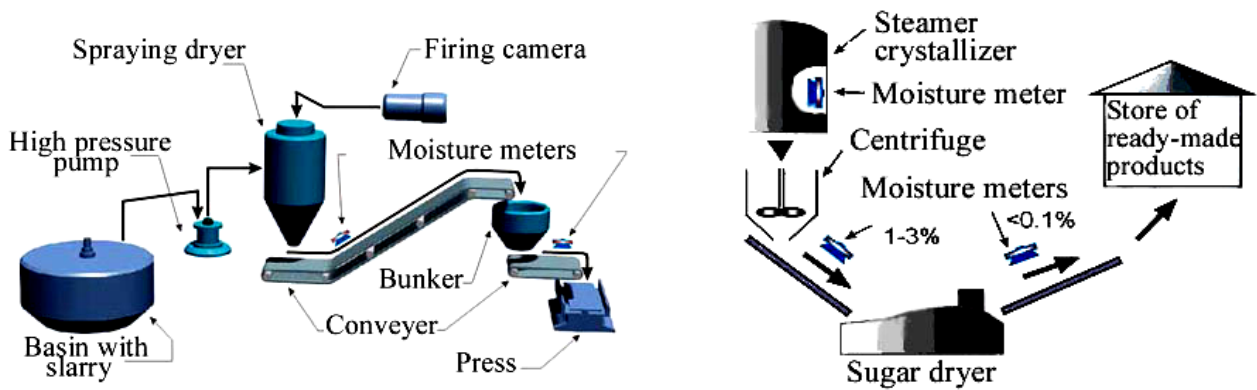

in production of ceramic tile

in production of sugar

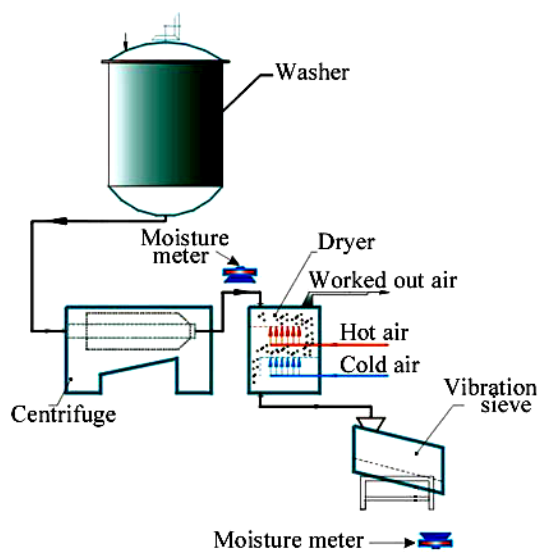

in production of polymers

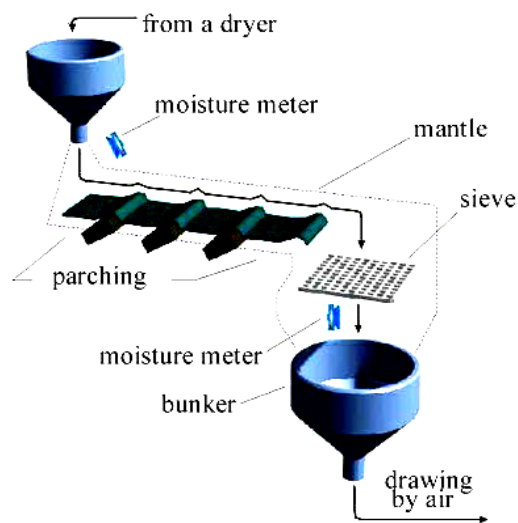

in production of milk powder